

EXTEGRA IP dynamic 9000 FX

www.boschsecurity.com



BOSCH
Invented for life



- ▶ High-performance camera with 1080p25/30 HD resolution and HDR in an explosion-proof housing of either anodized aluminum or ruggedized, electropolished 316L stainless steel.
- ▶ All models hold international certifications for use in hazardous environments.
- ▶ Easy one-piece installation with a motorized zoom lens and autofocus mechanism.
- ▶ Optional integrated Ethernet provides versatility for longer cable runs or where electromagnetic interference is a concern.
- ▶ ONVIF conformant; provides interoperability with other conformant systems.

The EXTEGRA IP dynamic 9000 FX is a high-performance, smart surveillance, fixed camera system for explosive environments. The professional-grade imaging platform uses the latest technology in intelligent imaging and video streaming and is capable of delivering 1080p25/30 or 720p50/60 HD resolution in environments with extreme ambient challenges. The camera holds all major international explosion-protected certifications for safe use in almost any region of the world. In addition, the camera complies to industry standards such as Type 6P and IP68 ratings.

The camera gives you the confidence to ensure a safe workplace while maintaining image quality in the world's most volatile locations.

Functions

High dynamic range models

Dynamic models have a full 1080p25/30 HD imaging platform with multiple exposures capable of delivering high dynamic range (HDR) video in scenes with simultaneous bright and dark areas. When operated in

HDR mode, the camera makes multiple, simultaneous exposures of the same scene to capture details in both bright and dark parts of the scene.

Integrated Zoom lens series and Auto Focus

EXTEGRA IP 9000 has a 30x optical Zoom lens (12x digital zoom) and an Auto Focus mechanism that allows installers to change the camera's field of view (FOV) remotely without needing to make lens adjustments manually in the field. All lens configurations are possible from the head end system. When the Auto Focus feature is selected in the camera's configuration, the camera continuously adjusts the lens to the correct image focus.

Intelligent Defog

With the Intelligent Defog mode feature, visibility can be improved significantly when viewing foggy or other low-contrast scenes.

Users can configure the mode to be active continuously, or to activate automatically when the video analytics in the camera detect fog and add light to the video image (and then deactivate when the fog clears or the scene changes).

Sodium vapor lamp white balance

The camera is an exceptional performer when capturing video under a sodium vapor lamp (a street lamp or tunnel lamp, for example). Images under these conditions may have a yellowish tint, which can make identification difficult. In the Sodium Vapor White Balance mode, the camera automatically compensates for the light from a sodium vapor lamp to restore objects to their original color.

Five (5) pre-programmed user modes

Five pre-programmed but configurable user modes, optimized with the best settings for a variety of typical applications, make on-site programming easy and user-friendly. Users select from the menu the mode that best defines the environment in which the camera is installed:

- Outdoor – General day-to-night changes with sun highlights and street lighting
- Indoor – Ideal mode for indoor applications where lighting is constant and not changing
- Low light – Optimized for sufficient details at low light
- Motion – Monitoring traffic or fast moving objects; motion artifacts are minimized
- Vibrant – Enhanced contrast color reproduction and sharpness

Users have the ability to customize these modes, if necessary, for the specific requirements of the site.

Sophisticated alarm responses

The camera supports advanced alarm control that uses sophisticated rules-based logic to determine how to manage alarms. In its most basic form, a “rule” could define which input(s) should activate which output(s). In a more complex form, inputs and outputs can be combined with pre-defined or user-specified commands to perform advanced camera functions.

Intelligent Dynamic Noise Reduction reduces bandwidth and storage requirements

The camera uses Intelligent Dynamic Noise Reduction which actively analyzes the contents of a scene and reduces noise artifacts accordingly.

The low-noise image and the efficient H.264 compression technology provide clear images while reducing bandwidth and storage by up to 50% compared to other H.264 cameras. This results in reduced-bandwidth streams that still retain a high image quality and smooth motion. The camera provides the most usable image possible by cleverly optimizing the detail-to-bandwidth ratio.

Content Based Imaging Technology

Content Based Imaging Technology (CBIT) is used to radically improve image quality in all lighting conditions and to identify areas for enhanced processing. The camera examines the scene using intelligent video analytics and provides feedback to re-tune the image processing. This provides better detail in the areas that matter and better all-round performance.

Advanced streaming

The camera offers advanced streaming capabilities so that you can configure the camera to take advantage of the latest network technology.

The camera is designed on the most efficient and powerful H.264 encoding platform capable of delivering high-quality HD video with very low network load. The new intelligent encoding capabilities drops the bandwidth consumption to extremely low levels if the camera detects no motion in the scene.

The camera is capable of quad streaming which allows the camera to be configured to deliver independent, configurable streams for live viewing, recording, or remote monitoring on constrained bandwidths.

With built-in Intelligent Video Analysis (IVA), the camera reinforces the concept of Intelligence at the Edge. IVA is Bosch’s state-of-the-art intelligent video content analysis technology. With IVA, the camera reliably detects and analyzes moving objects while suppressing unwanted alarms from spurious sources in the image. IVA also allows the camera to detect multiple object behaviors including idle and removed objects, loitering, multiple line crossing, and trajectories. IVA supports BEV (Bird’s-Eye-View) People Counter and Assisted Self-Calibration.

Configurable detection filters improve reliability and reduce operator work load.

Advanced networking capabilities

The camera offers Quality of Service (QoS) configuration options to ensure fast network response to camera data and images. Quality of Service (QoS) is the set of techniques to manage network resources. QoS manages the delay, delay variation (jitter), bandwidth, and packet loss parameters to guarantee the ability of a network to deliver predictable results. QoS identifies the type of data in a data packet and divides the packets into traffic classes that can be prioritized for forwarding.

The camera also supports the IPv6 internet-layer protocol for packet-switched internetworking across multiple IP networks. IPv6 uses 128-bit addresses (IPv4 uses 32-bit addressing), which allows for many more devices and users on the network as well as extra flexibility in allocating addresses and efficiency for routing traffic.

The camera maximizes your security investment by integrating with Bosch video products including Bosch Video Client, Bosch Video Management System, and the Bosch Recording Station, as well as the full range of Bosch video-over-IP products.

ONVIF conformant

The camera conforms to the ONVIF (Open Network Video Interface Forum) specification which guarantees interoperability between network video products regardless of manufacturer. The ONVIF Profile S specification allows easy integration with other conformant devices and VMS. ONVIF conformant devices are able to exchange live video, audio, metadata, and control information, and ensure that

they are automatically discovered and connected to network applications such as video management systems.

Dual power options

The camera can be powered by a network compliant to High Power-over-Ethernet (Bosch’s version of High PoE) using a Bosch model of High PoE Midspans (sold separately). With this configuration, only a single (Cat5e/Cat6e) cable connection is required to view, to power, and to control the camera.

The camera can also accept a standard 24 VAC power source if a High PoE network interface will not be used. User-supplied wiring must be in compliance with electrical codes (Class 2 power levels).

For maximum reliability, the camera can be connected simultaneously to a High PoE Midspan and a separate 24 VAC power source. If High PoE and 24 VAC are applied simultaneously, the camera usually selects auxiliary input (24 VAC) and will draw minimal power from the High PoE Midspan. If the 24 VAC power source fails, the camera switches power input seamlessly to High PoE. After the 24 VAC power source is restored, the camera switches power input again to 24 VAC.

Refer to the table in the Installation/configuration notes section for more information.

Global explosion protection certification

The camera holds all major international certifications for installation of explosion-protected products. As a UL-listed product, the camera is certified for the division and zone system per the NEC standards. For Europe, it has ATEX certification. The camera has been tested against and conforms to the international IECEx scheme. For Brazil, the camera holds the INMETRO certification.

Extreme environment ready

The camera is available with an explosion-proof housing of either anodized aluminum (for less corrosive environments) or ruggedized, electropolished 316L stainless steel (which offers excellent corrosion protection in highly corrosive environments).

Subjected and certified to rigorous immersion tests, the camera has Type 6P and IP68 ratings for wet locations.

As with all Bosch products, the camera is designed using the industry’s best design process and is subjected to the most stringent testing standards such as HALT (highly accelerated life testing), which pushes the limits of products to ensure reliability throughout their lifetime.

For operation in areas prone to vibration, the camera has been tested to the IEC 60068 standards applicable to vibration and shock.

Ease of installation and servicing

A single pre-assembled unit with an integrated junction box, the camera is designed to be easy to install. Four 3/4-in. conduit openings provide access to

the convenient terminal block for all power, alarm, and Ethernet cable connections. (An M20 adapter is also included.)

Various mounting options with the mount adapter

The EXS-ADPT is a stainless steel mount adapter that allows installers to mount an EXTEGRA IP 9000/EX65 device to a MIC wall mount bracket (MIC-WMB) and then to one of the following mounting brackets originally designed for the MIC Series of cameras:

- Spreader plate (MIC-SPR), for installation on a wall
- Corner mount bracket (MIC-CMB), for installation in a corner
- Pole mount bracket (MIC-PMB), for installation on the side of a CCTV pole

Refer to the datasheet “MIC Mounting Brackets and Other Accessories” for details about these mounts.

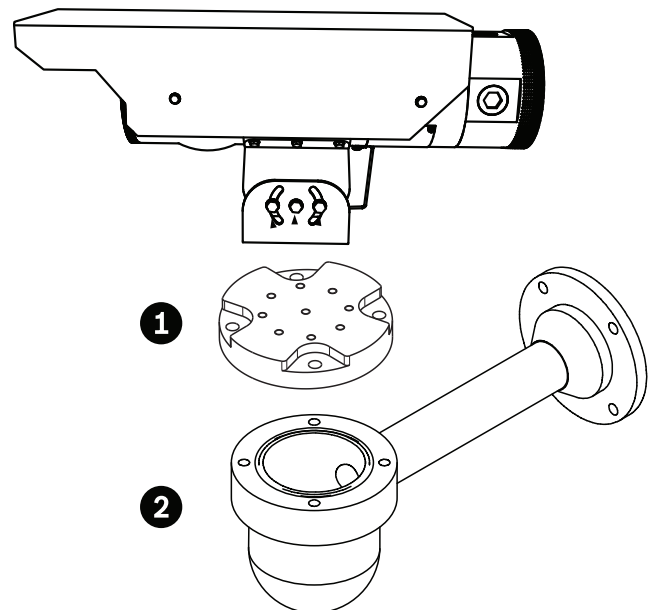

EXTEGRA IP 9000/EX65 device to EXS-ADPT (1) to MIC Wall Mount Bracket (MIC-WMB) (2)

Certifications and approvals

Region	Certification
Europe	CE Declaration of Conformity, ATEX
USA	UL, FCC
Canada	cUL
Brazil	INMETRO
International	IECEX

Electromagnetic Compatibility (EMC)

Emission	EN 55022:2010 Class B, FCC Part 15 Class A
Immunity	EN 61000-4, EN 50130-4:2011 EN 50121-4: 2006 (Railway applications)

Safety	UL 508, CAN/CSA C22.2 No. 60065-03 IEC 60950-1
---------------	---

Environmental

UL Type Rating Type 4X, Type 6P
Ingress Protection Rating IP68
Sinusoidal Vibration – tested to IEC 60068-2-6; frequency range 10 to 150 Hz, .5G
Shock – tested to IEC 60068-2-27; 10 G



File # E333679
Class I, Groups C and D; Class II, Groups E, F, and G;
Class III
Class I, Zone 1, AEx db IIB T6; Ex db IIB T6 X
Zone 21, AEx tb IIIC T85°C Db
Ex tb IIIC T85°C Db X
IP68, Type 4X, Type 6P

ATEX Certification

DEMKO 15 ATEX 1444X

0539 (Ex) II 2 G Ex db IIB T6 Gb

(Ex) II 2 D Ex tb IIIC T85°C Db

**IECEX Certification**

IECEX UL 15.0001X

Ex db IIB T6 Gb; Ex tb IIIC T85°C Db

InMetro Portaria No. 179 2010

UL-BR 15.0086X

Ex d IIB T6 Gb; Ex tb IIIC T85°C Db

Relevant standards associated with the HazLoc, ATEX, IECEX, and INMETRO certifications:

UL 1203, Fifth Edition, Revised 2013

UL 60079-0 Sixth Edition

UL 60079-1 Sixth Edition

ANSI/ISA-60079-31 2009

CAN/CSA C22.2 No. 30-M1986, Reaffirmed 2012

CAN/CSA C22.2 No. 25-1966, Reaffirmed 2009

CAN/CSA C22.2 No. 60079-0-11

CAN/CSA C22.2 No. 60079-1-11

CAN/CSA C22.2 No. 60079-31:12 First Edition

EN 60079-0:2012+A11:2013

EN 60079-1:2007

EN 60079-31:2009

IEC 60079-1:2011 Edition 6

IEC 60079-1:2007-04 Edition 6

IEC 60079-31:2008 Edition 1

ABNT NBR IEC 60079-0:2008

ABNT NBR IEC 60079-1:2009

ABNT NBR IEC 60079-31:2011

Maximum ambient temperature (24VAC)

Aluminum -50 °C ≤ Ta ≤ +60 °C

Stainless Steel -50 °C ≤ Ta ≤ +55 °C

Ambient operating range (PoE)

Aluminum -40 °C ≤ Ta ≤ +60 °C

Stainless Steel -40 °C ≤ Ta ≤ +55 °C

Region	Certification	
Europe	CE	IECEX Certificate
USA	UL	DEMKO 15 ATEX 1444X Rev. 0 DEMKO Certificate
	UL	20160908-E333679 UL CERTIFICATE OF COMPLIANCE

Installation/configuration notes

The table below identifies the power devices that can be connected simultaneously to the camera.

If power is supplied from:	Camera can receive power simultaneously from:
60 W midspan (NPD-6001A)	24 VAC PSU (VG4-A-PSU1, VG4-A-PSU2)
95 W midspan (NPD-9501A)	

Technical specifications**EXTEGRA IP dynamic 9000 FX camera**

Imager	1/2.8-type Exmor CMOS sensor
Effective Picture Elements (Pixels)	1944 x 1224 (2.38 MP)
Lens	30x Zoom 4.3 mm to 129 mm F1.6 to F4.7
Field of View (FOV)	2.3° to 65°
Focus	<i>Automatic with manual override</i>
Iris	<i>Automatic with manual override</i>
Digital Zoom	12x

Sensitivity / Minimum Illumination (typical)	30 IRE	50 IRE
Day Mode (Color)		
Fixed shutter 1/30, High Sensitivity mode On	0.066 lux	0.209 lux
Fixed shutter 1/30, High Sensitivity mode Off	0.26 lux	0.83 lux
Fixed shutter ¼, High Sensitivity mode On	---	0.026 lux
Fixed shutter ¼, High Sensitivity mode Off	---	0.104 lux
SensUp On, High Sensitivity mode On	0.0103 lux	0.033 lux
SensUp On, High Sensitivity mode Off	0.041 lux	0.104 lux
Night Mode (Black and white)		
Fixed shutter 1/30, High Sensitivity mode On	0.033 lux	0.104 lux
Fixed shutter ¼, High Sensitivity mode On	0.0026 lux	---
SensUp On, High Sensitivity mode On	0.00129 lux	0.0041 lux

Additional Camera Settings

Gain Control	Auto/Manual/Max
Aperture Correction	Horizontal and vertical
Electronic Shutter Speed (AES)	1/1 sec to 1/10000 sec (22 steps)
Dynamic Range	90 dB typical
Signal-to-Noise Ratio (SNR)	>50 dB
Backlight Compensation (BLC)	On/Off
White Balance	2000 K to 10,000 K ATW, AWB Hold, Extended ATW, Manual, Sodium Lamp Auto, Sodium Lamp
Day/Night	Monochrome, Color, Auto
Defog mode feature	Improves visibility when viewing foggy or other low-contrast scenes.

Electrical

Input Voltage	24 VAC ± 10%, 50/60 Hz or Single Ethernet High PoE cable connection
Power Consumption	18W / 28VA (no heaters) 68W / 85VA (with 24VAC and heaters ON) 48W / 50VA (with High PoE and heaters ON)

Surge Suppression

Protection on Alarm Inputs	Peak current 17 A, peak power 300 W (8/20 µs)
Protection on Alarm Outputs	Peak current 2 A, peak power 300 W (8/20 µs)
Protection on Relay Output	Peak current 7.3 A, peak power 600 W (10/1000 µs)
Protection on Power Input	Peak current 7.3 A, peak power 600 W (10/1000 µs)
10/100 Ethernet Data Lines	Peak current 14 A, peak power 200 W (8/20 µs)

Communications / Software Control

Camera Setup/Control	Via Internet Explorer web browser version 7.0 or later, Bosch Configuration Manager, Bosch Video Management System (BVMS), Bosch Video Client (BVC), or support for third party software
Software Update	Network firmware upload

Network

Standards / Video compression	H.264 (ISO/IEC 14496-10), M-JPEG, JPEG
Streaming	Four (4) individually configurable streams in H.264 and M-JPEG, configurable frame rate and bandwidth:
Two independently configurable H.264 streams	Stream 1: H.264 Main Profile (MP): <ul style="list-style-type: none"> 91xx models: 720p50/60 92xx models: 1080p25/30 Stream 2: H.264 Baseline Profile plus (BP+) or H.264 MP Standard Definition (SD) or Copy of Stream 1
Two additional streams	M-JPEG stream and High Definition (HD) I-frame only stream

Resolution (H x V)

1080p HD	1920 x 1080
720p HD	1280 x 720
432p SD	768 x 432

288p SD	512 x 288
144p SD	256 x 144

Network

Protocols	IPv4, IPv6, UDP, TCP, HTTP, HTTPS, RTP/RTCP, IGMP V2/V3, ICMP, ICMPv6, RTSP, FTP, Telnet, ARP, DHCP, APIPA (Auto-IP, link local address), NTP (SNTP), SNMP (V1, MIB-II), 802.1x, DNS, DNSv6, DDNS (DynDNS.org, selfHOST.de, no-ip.com), SMTP, iSCSI, UPnP (SSDP), DiffServ (QoS), LLDP, SOAP, Dropbox, CHAP, digest authentication
Encryption	TLS 1.0, SSL, DES, 3DES
Ethernet	10/100 Base-T, auto-sensing, half/full duplex
Connectivity	ONVIF Profile S, Auto-MDIX
Ethernet Connector	RJ45
GOP Structure	IP, IBP, IBBP
Data Rate	9.6 kbps to 6 Mbps
Overall IP Delay	240 ms

Audio

- Standard	G.711, 8 kHz sampling rate L16, 16 kHz sampling rate AAC, 16 kHz sampling rate
- Signal-to-Noise Ratio	>50 dB
- Audio Streaming	Bidirectional (full-duplex)

Local Storage

Memory Card Slot	User-supplied SD/SDHC/SDXC memory card (maximum 2TB – SDXC)
Recording	Continuous recording of video and audio, alarm/events/schedule recording
Preset Zoom Positions	256
Camera Setup / Control	100 Base Tx Ethernet
Supported Languages	English, Czech, Dutch, French, German, Italian, Polish, Portuguese, Russian, Spanish

User Connections

Power, Network	10/100 Base-T, auto-sensing, half/full duplex
Power, Camera	24 VAC (power supply)
Video and Control	RJ-45 100 Base-TX Ethernet

Alarm Inputs	Three (3) non-supervised Programmable for "normally open" or "normally closed"
Alarm Outputs	Two (2) open collector/transistor outputs 32 VDC @ 150 ma max. 1 dry contact relay
Audio	1 x mono line in, 1 x mono line out
Signal line in	12 kOhm typical, 1 Vrms max
Signal line out	1 Vrms at 1.5 kOhm, typical

Environmental

Ingress Protection Rating	IP68
UL Type Rating	Type 4X, Type 6
Operating Temperature	Aluminum models, 24VAC: -50 °C to +60 °C (-58 °F to +140 °F) Aluminum models, PoE: -40 °C to +60 °C (-40 °F to +140 °F) Stainless Steel models, 24VAC: -50 °C to +55 °C (-58 °F to +131 °F) Stainless Steel models, PoE: -40 °C to +55 °C (40 °F to +131 °F)
Storage Temperature	-55 °C to +70 °C (-67 °F to +158 °F)
Operating Humidity	0 to 100% relative (condensing, after installed and sealed)
Storage Humidity	20 to 98% relative (non-condensing)

Construction

Dimensions (L x W x H)	381 x 114 x 114 mm (11.01 x 4.5 x 4.5 in.) without sunshield or mounting cradle
Weight	Stainless Steel: 12.9 kg (28.5 lb) Aluminum: 6.4 kg (14 lb)
Construction Material	Electropolished 316L Stainless Steel or Anodized Aluminum
Bracket	Pan(±36°)/Tilt(±45°), mounting cradle included
View Window	9-mm thick borosilicate float glass
Cable Entry	Four (4) 3/4-in. NPT entries; Thread Adapter (3/4 in. NPT to M20) included

Ordering information**NXF-9230-A4 EXTEGRA IP dynamic 9000 FX**

Explosion-protected, fixed camera system with high dynamic range (HDR). 1080p25/30 HD resolution, integrated 30x optical zoom lens, IVA, PoE, and easy installation for explosive environments. Aluminum housing.

Order number **NXF-9230-A4**

NXF-9230-S4 EXTEGRA IP dynamic 9000 FX

Explosion-protected, fixed camera system with high dynamic range (HDR). 1080p25/30 HD resolution, integrated 30x optical zoom lens, IVA, PoE, and easy installation for explosive environments. Stainless Steel housing.

Order number **NXF-9230-S4**

Accessories**NPD-6001A High PoE midspan 60 W, single port, AC in**

High Power, 60 W Single Port PoE Midspan with AC in

Order number **NPD-6001A**

NPD-9501A High PoE midspan 95 W, single port, AC in

High PoE, 95 W, Single Port Midspan with AC in

Order number **NPD-9501A**

VG4-A-PSU1 120 VAC Power Supply Unit

Power supply with transformer, 120 VAC input, for an AUTODOME or MIC7000 Series PTZ camera. White, aluminum enclosure with cover, rated IP66 and IK 08. 100 W output. Optional trim skirt (sold separately).

Order number **VG4-A-PSU1**

VG4-A-PSU2 230 VAC Power Supply Unit

Power supply with transformer, 230 VAC input, for an AUTODOME or MIC7000 Series PTZ camera. White, aluminum enclosure with cover, rated IP66 and IK 08. 100 W output. Optional trim skirt (sold separately).

Order number **VG4-A-PSU2**

EXS-ADPT EX65-to-MIC Mount Adapter, Stainless Steel

Adapter that allows the EX65 camera or illuminator to be mounted on a MIC wall mount bracket (MIC-WMB) and then to one of a variety of other MIC Series mounting brackets.

Order number **EXS-ADPT**

MIC-CMB-S Corner Mount Bracket, Stainless Steel

Corner mount bracket, grade 316 stainless steel

Order number **MIC-CMB-S**

MIC-WMB-S Wall Mount Bracket, Stainless Steel

Wall mount bracket, grade 316 stainless steel (Requires MIC-SPR or MIC-PMB for secure mounting because of weight.)

Order number **MIC-WMB-S**

MIC-PMB Pole Mount Bracket

Pole mount bracket (includes 2 x 455 mm stainless steel banding straps for pole diameters 75 to 145 mm)

Order number **MIC-PMB**

MIC-SPR-S Spreader Plate, Stainless Steel

316L stainless steel spreader plate suitable for brickwork surface mounting, plain finish

Order number **MIC-SPR-S**

Represented by:

Europe, Middle East, Africa:
Bosch Security Systems B.V.
P.O. Box 80002
5600 JB Eindhoven, The Netherlands
Phone: + 31 40 2577 284
emea.securitysystems@bosch.com
emea.boschsecurity.com

Germany:
Bosch Sicherheitssysteme GmbH
Robert-Bosch-Ring 5
85630 Grasbrunn
Germany
www.boschsecurity.com

North America:
Bosch Security Systems, Inc.
130 Perinton Parkway
Fairport, New York, 14450, USA
Phone: +1 800 289 0096
Fax: +1 585 223 9180
onlinehelp@us.bosch.com
www.boschsecurity.us

Asia-Pacific:
Robert Bosch (SEA) Pte Ltd, Security Systems
11 Bishan Street 21
Singapore 573943
Phone: +65 6571 2808
Fax: +65 6571 2699
apr.securitysystems@bosch.com
www.boschsecurity.asia